

Product Data Sheet**PL2503**

- Single chip Hi-Speed USB 2.0 to Serial (RS232/RS422/RS485) asynchronous serial data transfer interface.
- Fully Compliant with USB 2.0 specification (Hi-Speed Mode).
- UHCI/OHCI (USB 1.1), EHCI (USB 2.0), xHCI (USB 3.0) Host Controller Compatible.
- Integrated USB 2.0 PHY.
- Integrated 5V to 3.3V Regulator.
- Implements USB protocol composite device:
 - Communication Device Class (CDC) - Abstract Control Model (ACM) subclass for virtual COM port.
 - USB Mass Storage Device Class (MSC) for file storage.
- Driver Support:
 - Built-in USB CDC-ACM class inbox driver (Virtual COM Port) in Windows¹, Mac, Android, and Linux.
 - Prolific's royalty-free CDC-ACM proprietary driver for chip full-feature support.
- On-chip 24KB embedded Flash:
 - For writing and storing custom device startup configuration (optional) like USB VID/PID, Serial Number, Product String, and other device configurations.
 - For storing Windows INF driver and Readme files (optional).
- Supports external SPI Flash up to 16MB
 - For writing and storing custom device startup configuration (optional) like USB VID/PID, Serial Number, Product String, and other device configurations.
 - For storing larger size user files.
- Embedded Flash or external SPI Flash can emulate as read-only USB mass storage drive to access factory pre-installed user files.
- USB to RS232 Serial Full UART interface:
 - Full-duplex transmitter and receiver (TX and RX).
 - Six MODEM control pins (RTS, CTS, DTR, DSR, DCD, and RI).
 - 5, 6, 7, or 8 data bits.
 - Odd, Even, Mark, Space, or None parity mode.
 - One, one and a half, or two stop bits.
 - Parity error, frame error, and serial break detection.
 - Programmable baud rate from 75bps to 6Mbps.
 - External RS232 driver power down control.
- Supports RS422/RS485 UART serial interface.
- Supports additional RS232 UART interface (TX-RX Pins Only)
 - Full-duplex transmitter and receiver (TX and RX) of up to 115200bps
- Transmit (TX) and Receive (RX) LED status drive signal pins for both UART interfaces.
- Extensive flow control mechanism:
 - Automatic hardware flow control with CTS/RTS or DSR/DTR.
 - Automatic software flow control with XON/XOFF.
 - Inbound data buffer overflow detection.
- 512-byte data buffers (inbound and outbound).
- Supports USB Selective Suspend (Run-Time Power Management)².
- Four General Purpose I/O (GPIO) pins for user-defined application².
- 48-pin LQFP IC packages (RoHS compliant and Pb-free Green Compound)

¹ Windows requires vendor custom INF to install.

² Need to use Prolific proprietary driver.

Ordering Information

Product	Package Type	Ordering Number
PL2503-LQFP48	48-pin LQFP	PL2503A2LMG7P1

Table of Contents

Ordering Information	2
1. Overview	5
1.1 Features	6
1.2 Product Application	7
2. Functional Block Diagram.....	8
3. Pin Diagram.....	9
4. Pin Assignment & Description.....	10
4.1 USB2.0 PHY Related Pins.....	10
4.2 UART Related Pins.....	10
4.3 SPI Flash Pins	10
4.4 GPIO Pins.....	11
4.5 System Pins	11
5. USB to RS232 Application Example.....	12
6. USB Mass Storage Drive Emulation.....	13
7. Device Configuration.....	14
8. Link Status LED	17
9. Data Formats and Baud Rate Table	18
10. Electrical Characteristics	19
10.1 Absolute Maximum Rating	19
10.2 Recommended Operating Condition.....	19
10.3 DC Characteristics of 3.3V I/O Cells	19
10.4 I/O Description.....	20
11. Outline Diagram	21

List of Figures

Figure 2-1 Functional Block Diagram	8
Figure 3-1 PL2503 Pin Diagram LQFP48.....	9
Figure 5-1 USB to RS232 Converter Example	12
Figure 7-1 PL2503 MFG Tool Program	14
Figure 8-1 Link Status LED	17
Figure 11-1 Outline Diagram of LQFP48 (7x7mm)	21

List of Tables

Table 4-1 USB2.0 PHY Related Pins	10
Table 4-2 UART Related Pins	10
Table 4-3 SPI Pins	10
Table 4-4 GPIO Pins	11
Table 4-5 System Pins	11
Table 6-1 Config Writer Program Control Buttons	15
Table 6-2 User Configurable USB Descriptors	15
Table 6-3 User Configurable Device Function	16
Table 7-1 Link Status LED Behavior	17
Table 8-1 PL2503 Supported Data Formats	18
Table 8-2 Baud Rate Settings (Supported by Prolific Driver)	18
Table 10-1 Absolute Maximum Ratings	19
Table 10-2 Recommended Operating Conditions	19
Table 10-3 DC Characteristics of 3.3V I/O Cells	19
Table 10-4 I/O Description	20

1. Overview

PL2503 provides a convenient solution for connecting an RS232-like full-duplex asynchronous serial device to any Universal Serial Bus (USB) capable host. The PL2503 provides two UART serial interfaces with one full UART interface (RS232/RS422/RS485) and one TX-RX only interface. The PL2503 highly compatible vendor drivers could simulate the traditional COM port on most operating systems allowing the existing applications based on Serial COM port to easily migrate and be made USB ready. The PL2503 can also be installed using the built-in USB CDC-ACM inbox driver (Virtual COM Port) in Windows, Mac, Linux, and Android OS.

By taking advantage of USB bulk transfer mode, large data buffers, and automatic flow control, PL2503 is capable of achieving higher throughput compared to traditional UART (Universal Asynchronous Receiver Transmitter) ports. The flexible baud rate generator of PL2503 can be programmed to generate any rate between 75 bps to 6M bps.

PL2503 also implements a USB Mass Storage Device (MSC) class with on-chip embedded flash memory to eliminate the need for CDROM disc to store user files and program. Aside from the Virtual COM Port, the on-chip embedded memory of the PL2503 composite device can also emulate a USB mass storage drive to store the CDC-ACM INF file for Windows installation. The PL2503 also provides an SPI interface for external SPI Flash memory to store larger size software programs and Prolific's proprietary driver installer files. If the external SPI Flash is detected, the emulated mass storage device will automatically display the contents stored inside the SPI Flash instead of the on-chip embedded memory. This feature allows the customer end-product to be environmental-friendly and cost-effective.

With small power consumption in either operating or suspend mode, PL2503 is perfect for bus-powered operation with plenty of power left for the attached devices.

¹ Windows requires vendor custom INF to install.

1.1 Features

- Single-chip Hi-Speed USB 2.0 to Serial (RS232/RS422/RS485) asynchronous UART serial data transfer interface
- Fully Compliant with USB 2.0 specification (Hi-Speed Mode)
- UHCI/OHCI (USB 1.1), EHCI (USB 2.0), xHCI (USB 3.0) Host Controller Compatible
- Integrated USB 2.0 Transceiver
- Integrated 5V to 3.3V and 3.3V to 1.8V Regulator
- Implements USB protocol composite device:
 - Communication Device Class – Abstract Control Model (CDC-ACM) for Virtual COM Port
 - USB Mass Storage Device Class (MSC) for emulated removable drive (file storage)
- Driver Support:
 - Built-in USB CDC-ACM class inbox driver in Windows, Android, Mac, and Linux (Windows require vendor custom INF)
 - Prolific CDC-ACM royalty-free driver for chip full-feature support (Virtual COM Port, GPIO control, faster baud rate, better compatibility, etc.)
- On-chip 24KB Embedded Flash:
 - For writing and storing custom device startup configuration like USB VID/PID, Serial Number, Product String, and other device configurations
 - For storing Windows INF/Readme files
- Supports external SPI Flash up to 16MB:
 - For writing and storing custom device startup configuration like USB VID/PID, Serial Number, Product String, and other device configurations
 - For storing larger size user files (ie. Prolific proprietary driver and other user files)
- On-chip Embedded Flash and external SPI Flash can emulate as USB mass storage drive so end-user can access the stored driver and user files.
- Supports USB to RS232 Serial UART interface:
 - Full-duplex transmitter and receiver (TX and RX)
 - Six MODEM control pins (RTS, CTS, DTR, DSR, DCD, and RI)
 - 5, 6, 7, or 8 data bits
 - Odd, Even, Mark, Space, or None parity mode
 - One, one and a half, or two stop bits
 - Parity error, frame error, and serial break detection
 - Programmable from 75bps to 6Mbps
 - External RS232 driver power down control
 - Works with existing PC COM Port software applications
- Supports RS-422/RS-485 like serial interface (TX, DTR, and RTS pins should be externally pulled-up to 5V)
- Extensive flow control mechanism
 - Automatic hardware flow control with CTS/RTS or DSR/DTR
 - Automatic software flow control with XON/XOFF
 - Inbound data buffer overflow detection

- Supports additional RS232 UART interface (TX-RX Pins Only)
 - Full-duplex transmitter and receiver (TX and RX) of up to 115200bps
- Transmit (TX) and Receive (RX) LED status drive signal pins for both UART interfaces.
- 512-Byte data buffers in both inbound and outbound direction
- Supports USB Selective Suspend (Run-Time Power Management) by Prolific driver
- Connection status LED pins (TX and RX) for both UART interface
- Four GPIO (GP0, GP1, GP2, and GP3) pins
- 48-pin LQFP IC packages (RoHS compliant and Pb-free Green Compound)

1.2 Product Application

- Single-chip upgrade solution for legacy RS232 devices to USB interface
- USB to RS232/RS422/RS485 Converters/Cables/Dongles/Adapters
- MCU-based device to USB Interface
- Point-of-Sale (POS) Terminals/Printers
- USB Barcode and Smart Card Readers
- Healthcare/Medical USB Interface Data Transfer Cable
- Dual-UART Cable/Adapter/Converter

2. Functional Block Diagram

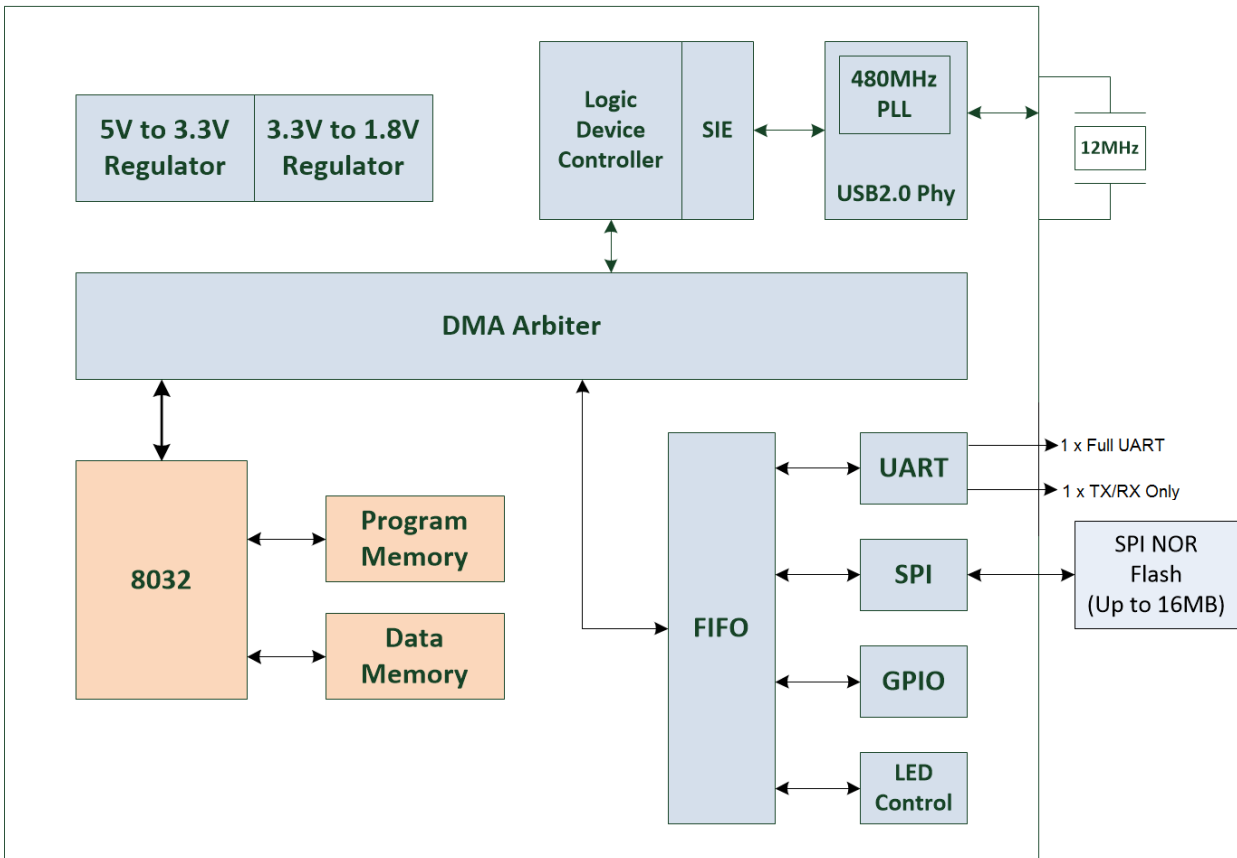

Figure 2-1 Functional Block Diagram

3. Pin Diagram

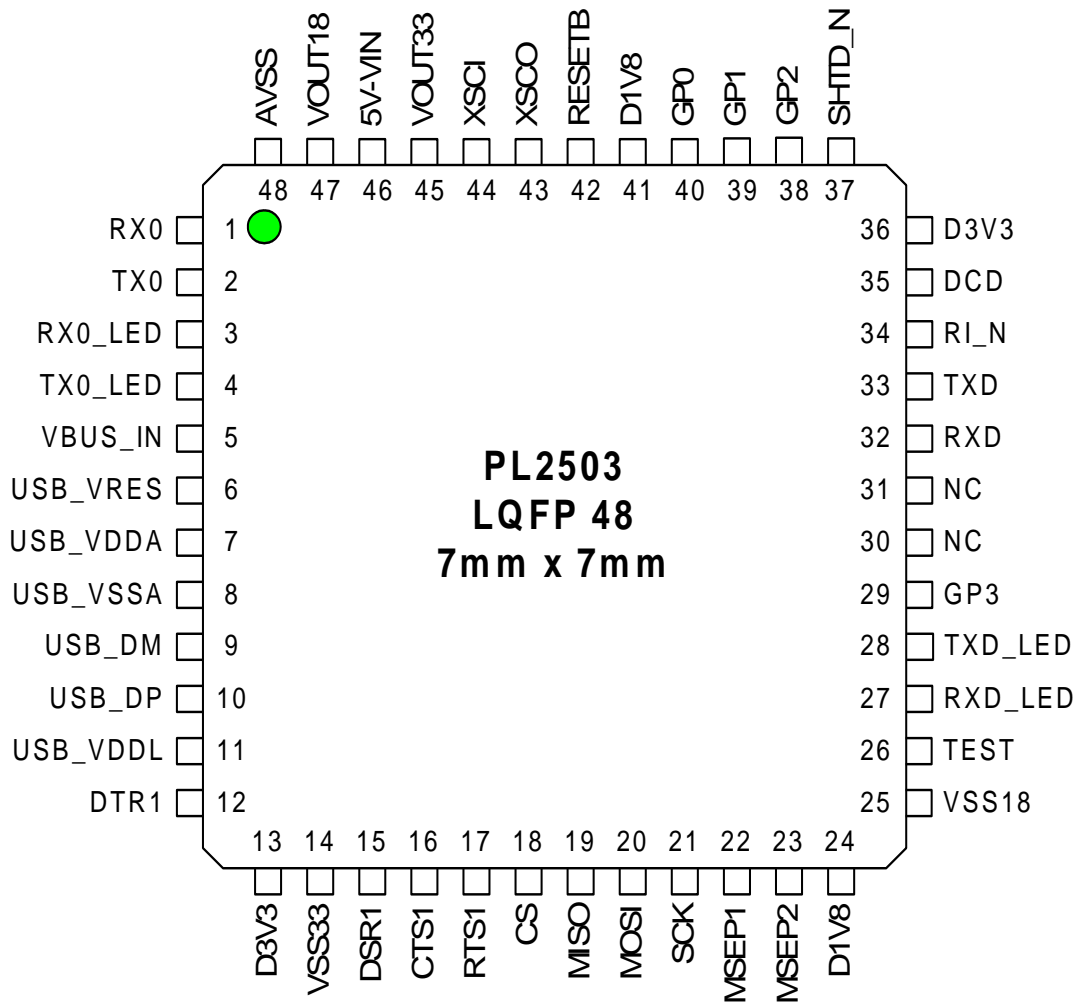

Figure 3-1 PL2503 Pin Diagram LQFP48

4. Pin Assignment & Description

Pin Type Abbreviation:

I: Input	O: Output	B: Bidirectional	A: Analog	P: Power	G: Ground
----------	-----------	------------------	-----------	----------	-----------

4.1 USB2.0 PHY Related Pins

Table 4-1 USB2.0 PHY Related Pins

Symbol	Type	Pin No	Description
VBUS_IN	I	5	USB VBUS input detector
USB_VRES	A	6	Connect to external 8.2K-ohm resistor for band-gap reference circuit
USB_VDDA	P	7	USB 3.3V analog power
USB_VSSA	G	8	USB analog ground
USB_DM	A	9	USB differential D-Minus connection
USB_DP	A	10	USB differential D-Plus connection
USB_VDDL	P	11	USB 1.8V digital power

4.2 UART Related Pins

Table 4-2 UART Related Pins

Symbol	Type	Pin No	Description
DTR	O	12	Serial Port Data Terminal Ready
DSR	I	15	Serial Port Data Set Ready
CTS	I	16	Serial Port Clear To Send
RTS	O	17	Serial Port Request To Send
RXD	I	32	Serial Port Receive Data
TXD	O	33	Serial Port Transmit Data
RI_N	I	34	Serial Port Ring Indicator (Remote Wakeup)
DCD	I	35	Serial Port Data Carrier Detect
TX0	I	2	Serial Port Transmit Data (TX/RX-Only Interface)
RX0	O	1	Serial Port Receive Data (TX/RX-Only Interface)

4.3 SPI Flash Pins

Table 4-3 SPI Pins

Symbol	Type	Pin No	Description
CS	O	18	SPI Chip Select
MISO	I	19	SPI Master In Slave Out
MOSI	O	20	SPI Master Out Slave In
SCK	O	21	SPI Clock

4.4 GPIO Pins

Table 4-4 GPIO Pins

Symbol	Type	Pin No	Description
GP3	B	29	GPIO 3
GP2	B	38	GPIO 2
GP1	B	39	GPIO 1
GP0	B	40	GPIO 0

4.5 System Pins

Table 4-5 System Pins

Symbol	Type	Pin No	Description												
MSEP1	I	22	Mass Storage Emulation Pin Option: <table border="1" style="width: 100%; border-collapse: collapse;"> <thead> <tr> <th>Options</th> <th>MSEP1</th> <th>MSEP2</th> </tr> </thead> <tbody> <tr> <td>Always Disable Mass Storage</td> <td>Don't Care</td> <td>Low</td> </tr> <tr> <td>Always Enable Mass Storage</td> <td>High</td> <td>High</td> </tr> <tr> <td>Disable Mass Storage if driver stored in mass storage has been installed.</td> <td>Low</td> <td>High</td> </tr> </tbody> </table>	Options	MSEP1	MSEP2	Always Disable Mass Storage	Don't Care	Low	Always Enable Mass Storage	High	High	Disable Mass Storage if driver stored in mass storage has been installed.	Low	High
Options	MSEP1	MSEP2													
Always Disable Mass Storage	Don't Care	Low													
Always Enable Mass Storage	High	High													
Disable Mass Storage if driver stored in mass storage has been installed.	Low	High													
MSEP2	I	23													
TXD_LED	O	28	TX Link Status LED for Full UART Interface												
RXD_LED	O	27	RX Link Status LED for Full UART Interface												
TX0_LED	O	4	TX Link Status LED for TX/RX-Only Interface												
RX0_LED	O	3	RX Link Status LED for TX/RX-Only Interface												
D3V3	P	13	3.3V Power												
VSS33	G	14	3.3V Ground												
D1V8	P	24	1.8V Power												
VSS18	G	25	1.8V Ground												
TEST	I	26	Test Mode enable (Active High)												
D3V3	P	36	3.3V Power												
SHTD_N	O	37	Transceiver Shutdown												
D1V8	G	41	1.8V Power												
RESETB	I	42	Hardware system reset (Active Low)												
XSCO	O	43	12MHz crystal out												
XSCI	I	44	12MHz crystal in												
VOU33	P	45	3.3V driving power												
VIN	P	46	5V input power source												
VOU18	P	47	1.8V driving power												
AVSS	G	48	Analog ground to regulator												

5. USB to RS232 Application Example

Following is an example of using the PL2503 as a USB to RS232 converter where a RS232 transceiver (Sipex SP3243) is used to convert the TTL levels serial interface of the PL2503 to RS232 levels. Contact Prolific FAE for the whole PCB Reference Design Kit and design support.

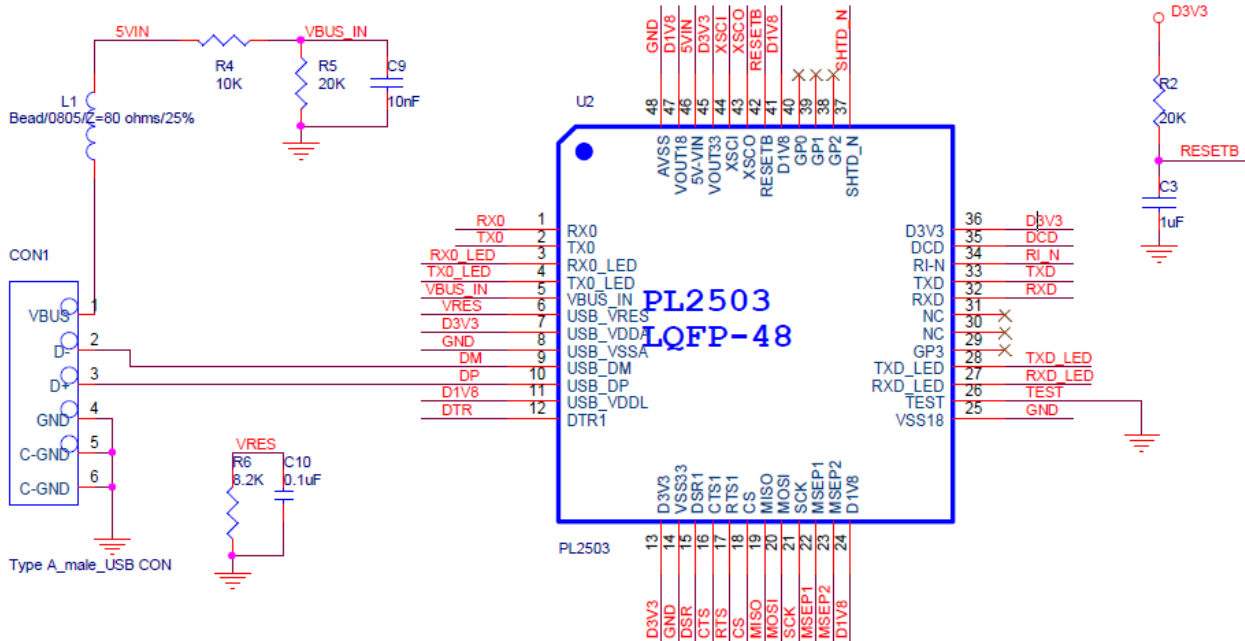

RS-232

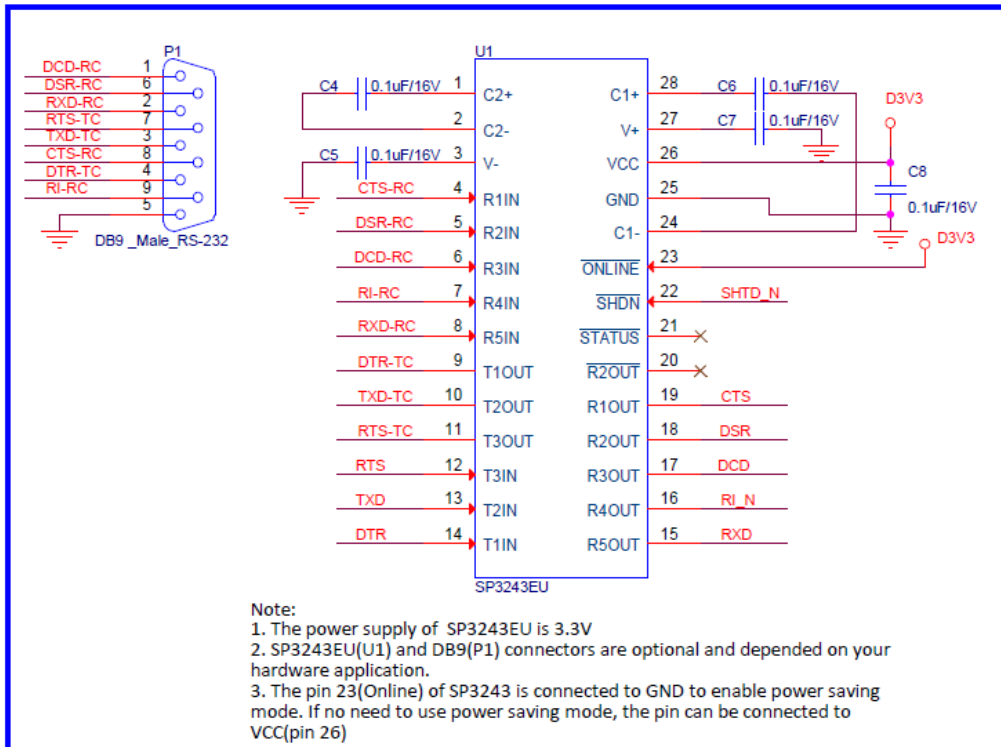

Figure 5-1 USB to RS232 Converter Example

6. USB Mass Storage Drive Emulation

PL2503 also implements a USB Mass Storage Device (MSC) class protocol to emulate a USB mass storage drive using the embedded 24KB memory or external SPI Flash to store end-user driver files and programs. The PL2503 provides an SPI interface for external SPI NOR Flash (up to 16MB) to store larger size software and driver installer files. One of the main files to be stored is the Prolific proprietary driver that offers more compatibility and customization. Another option is the PL2503 vendor INF file for Windows CDC-ACM inbox driver installation (Windows 10 does not require INF installation). This mass storage drive emulation feature helps eliminate the need for CDROM disc and allows the customer end-product to be environmental-friendly and cost-effective. If the external SPI Flash is detected, the emulated mass storage device will automatically display the contents stored inside the SPI Flash instead of the PL2503 internal memory. The stored files will be accessible as read-only files.

The PL2503 provides convenient pin options to configure the mass storage emulation feature. The default option is to automatically disable mass storage emulation once driver has been installed. Microsoft Windows disables the Selective Suspend feature if mass storage device is detected. Therefore, user needs to set the pin option to either “Always disable mass storage” or “Disable mass storage if driver has been installed” if selective suspend feature is desired.

Table 6-1 Mass Storage Emulation Pin Option

	MSEP1	MSEP2
Always disable mass storage	Don't Care	Low
Always enable mass storage	High	High
Disable mass storage if driver has been installed	Low	High

Prolific provides the PL2503 MFG Tool program to configure the embedded flash or external SPI flash to a USB mass storage drive (see next section). This tool allows vendors to customize the Disk Name of the Mass Storage drive and store up to 15 files into the memory. The total size depends on the size of the SPI flash (only up to 24KB using on-chip internal memory).

7. Device Configuration

Default configuration descriptors are pre-programmed and stored in the chip internal ROM and loaded during power-on reset or USB bus reset. Using the PL2503 MFG (Manufacturing) Tool program, several of the USB descriptors like Vendor ID (VID), Product ID (PID), Serial Number, and Product String as well as GPIO and Serial port pin settings, can be vendor customized and stored to the PL2503 on-chip embedded memory (no need for external EEPROM) or external SPI Flash. The PL2503 MFG Tool program can be requested from Prolific FAE or authorized distributor FAEs.

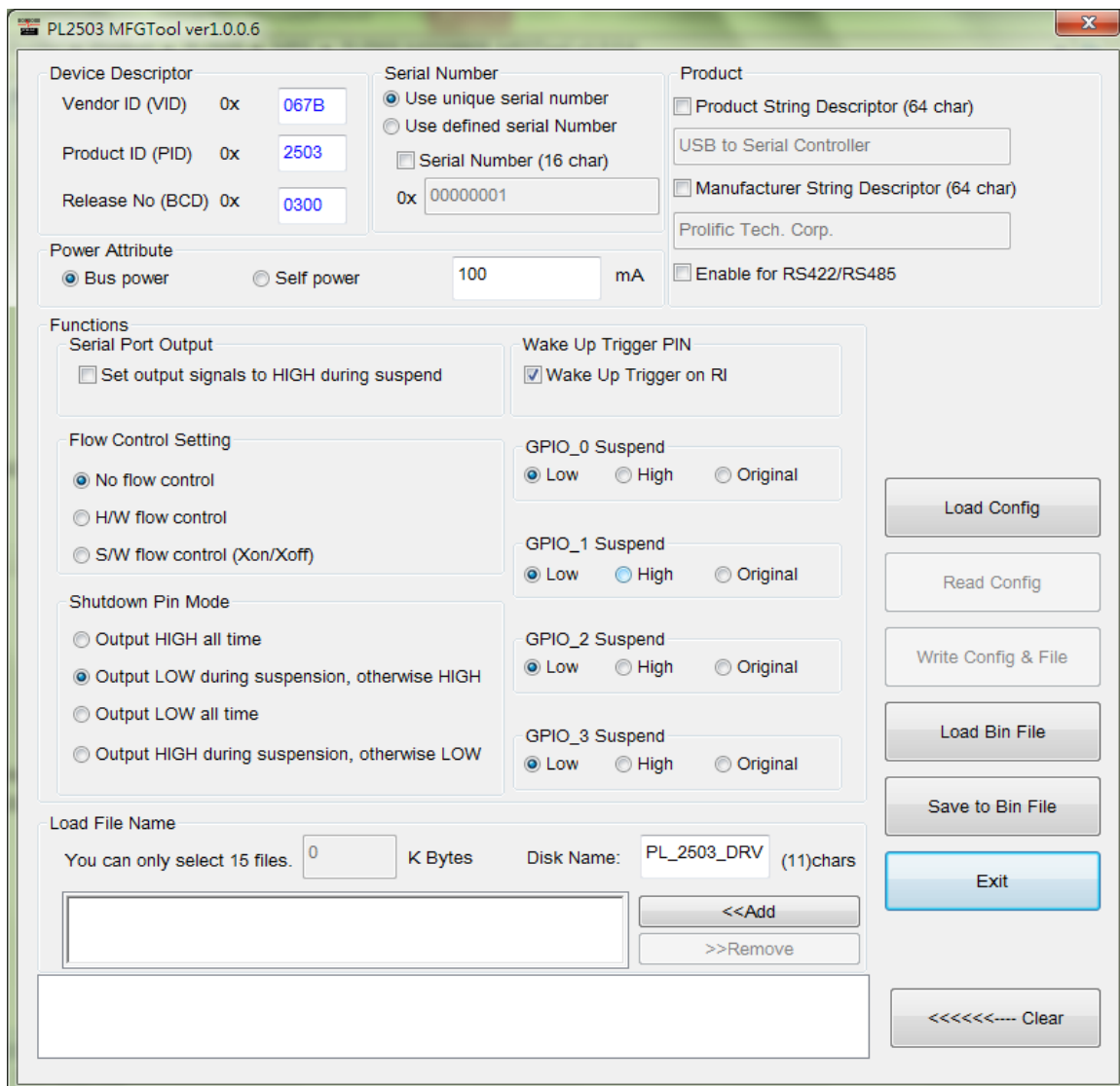

Figure 7-1 PL2503 MFG Tool Program

Table 7-1 Control Buttons

Button Function	Description
Load Config	This loads the preconfigured settings and BIN file saved previously.
Read Config	This reads configuration contents from embedded flash or SPI Flash.
Write Config & File	This writes the displayed configuration into the embedded flash or SPI Flash. End-user files will also be written to mass storage emulated drive.
Save to BIN File	This saves the displayed set configuration and mass storage files into a BIN file for later pre-loading use.
Exit	This closes the program.
Clear	This erases and clears the display shown on the box.

Table 7-2 User Configurable USB Descriptors

Descriptor	Default Value	Description
Vendor ID (VID)	0x067B	USB unique Vendor ID of Company or Manufacturer. This ID is applied and registered from USB-IF. Refer to this website for applying USB Vendor ID: http://www.usb.org/developers/vendor/
Product ID (PID)	0x2503	USB Product ID assigned by Company or Manufacturer
Release No. (BCD)	0x0300	This field reports the release number of the USB device. Do not modify this item.
Serial Number	Disabled	This field sets the product USB serial number. Entering a defined serial number allows the device to be assigned the same COM Port number even when plug to other USB ports of the same computer. <ul style="list-style-type: none"> ■ Use unique serial number ■ Use customer defined serial number
Product String Descriptor	USB-Serial Controller	This field when entered will be the string displayed by Windows and other OS when device is first detected and before driver is loaded or driver not installed
Manufacturer String Descriptor	Prolific Technology Inc.	This field will show the product manufacturer string.
Power Attribute	Bus Power	This field defines whether the device is self-powered or bus-powered.
USB Max Power	100mA	This item sets the USB device maximum power.

Table 7-3 User Configurable Device Function

Function	Default Value	Description
Enable for RS422/RS485	Disabled	Enable for RS422/RS485 design with RTS interface to Schmitt-Trigger Inverter. (see PL2503 reference design)
Serial Port Output	Disabled	This field allows to set the serial output pin signals to HIGH during suspend mode.
Flow Control Setting	No Flow Control	This option allows to set the flow control initial setting to none, H/W, or S/W control. Note: H/W and S/W flow control can also be set and configured on customer/user serial communication software.
Shutdown Pin Mode	Output LOW during suspend	This option allows setting the Shutdown pin (Pin 37) mode to Output HIGH or LOW on normal mode or Suspend mode.
Wake Up Trigger Pin	Enabled	This option allows user enabling remote wakeup function. When in suspend mode, Pull down RI_N to ground could trigger a wakeup event. NOTE: To support Selective Suspend function, you need to enable this option.
GPIO Pin	Low	These options allow setting the GPIO pin default state.

Table 7-4 Mass Storage Drive Emulation Configuration (Load File Name)

Function	Description
Disk Name	Allows you to set the drive name of the emulated drive that will appear on when you plug-in the device.
K Bytes	Shows the size of the added total files that you want to be stored into the emulated drive. Total files is maximum 15 files.
Add	Click this button to add files. Filenames must be maximum 8 characters (does not support long filenames). You also cannot add folders.
Remove	Click this button to remove selected files that you have added earlier.

Load File Name

You can only select 15 files. K Bytes Disk Name: (11)chars

E:\Prolific\Product\PL2503\Prolific Driver\SETUP.exe

NOTE: filename max 8 chars and no folders allowed.

8. Link Status LED

PL2503 has LED pins for link status indication. These pins are directly controlled by PL2503 internal logic and do not require driver control. Please refer to Table 8-1 for hardware behavior of the two LED pins.

Table 8-1 Link Status LED Behavior

LED Pin	Pin No	USB Link Up	USB Link Down	TX Transmitting	RX Receiving
TXD_LED	28	Low	High	Toggle (Blink)	Don't Care
RXD_LED	27	Low	High	Don't Care	Toggle (Blink)
TX0_LED	4	Low	High	Toggle (Blink)	Don't Care
RX0_LED	3	Low	High	Don't Care	Toggle (Blink)

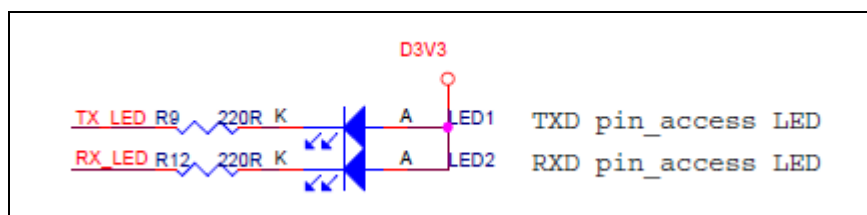

Figure 8-1 Link Status LED

9. Data Formats and Baud Rate Table

The PL2503 controller supports versatile data formats and has a programmable baud rate generator. The supported data formats are shown in **Table 9-1**. The programmable baud rate generator supports baud rates up to 6M bps as shown in **Table 9-2**.

Table 9-1 PL2503 Supported Data Formats

Data Formats	Description
Stop Bits	1, 1.5, 2
Parity Type	None, Odd, Even, Mark, Space
Data Bits	5, 6, 7, 8

Table 9-2 Baud Rate Settings (Supported by Prolific Driver³)

Baud Rates (bps)				
6000000	460800	134400	19200	1800
3000000	403200	128000	14400	1200
2457600	268800	115200	9600	600
1228800	256000	57600	7200	300
921600	230400	56000	4800	150
806400	201600	38400	3600	110
614400	161280	28800	2400	75

³ Baud rate not listed in this table requires customized proprietary driver from Prolific Technology, please contact Prolific FAE for driver customization support.

10. Electrical Characteristics

10.1 Absolute Maximum Rating

Table 10-1 Absolute Maximum Ratings

SYMBOL	DESCRIPTION	RATING	UNIT
V _{CCK}	Core Power Supply	-0.5 ~ 1.98	V
V _{CCK3IO}	Power Supply of 3.3 V I/O Cells	-0.5 ~ 3.6	V
T _{STG}	Storage Temperature	-65 ~ 150	°C

Notes:

- Permanent damage on devices may occur if the absolute maximum ratings are exceeded. These are only stress ratings and functional operation should be restricted within the conditions detailed in this table. Exposure to the absolute maximum rating conditions for extended periods of time may affect the reliability of the devices.
- The input and output negative voltage rating may be exceeded if the input and output currents under ratings are observed.

10.2 Recommended Operating Condition

Table 10-2 Recommended Operating Conditions

SYMBOL	PARAMETER	MIN	TYP	MAX	UNIT
V _{CCK}	Core Power Supply	1.62	1.8	1.98	V
V _{CCK3IO}	Power Supply of 3.3V	3.0	3.3	3.6	V
T _j	Junction Operating Temperature	-40	25	125	°C

10.3 DC Characteristics of 3.3V I/O Cells

Table 10-3 DC Characteristics of 3.3V I/O Cells

SYMBOL	PARAMETER	CONDITIONS	MIN	TYP	MAX	UNIT
V _{IL}	Input Low Voltage		-0.3	-	0.8	V
V _{IH}	Input High Voltage		2.0	-	5.5	V
V _{t-}	Schmitt-trigger negative to threshold voltage		1.14	1.21	1.25	V
V _{t+}	Schmitt-trigger positive to threshold voltage		1.47	1.53	1.57	V
V _{ol}	Output low voltage	I _{ol} = 4mA	-	-	0.4	V
V _{oh}	Output high voltage	I _{oh} = 4mA	1.8	-	-	V
R _{pu}	Input pull-up resistance		39	57	89	kΩ
R _{pd}	Input pull-down resistance		35	57	107	kΩ

10.4 I/O Description

Table 10-4 I/O Description

SYMBOL	TYPE	PIN NO.	DESCRIPTION
TX_LED	O	3	Pull-up
RX_LED	O	4	Pull-up
VBUS_IN	I	5	Schmitt-trigger, Pull-down
DTR	O	12	Pull-up
DSR	I	15	Pull-up
CTS	I	16	Pull-up
RTS	O	17	Pull-up
CS	O	32	Pull-up
MISO	I	33	Pull-up
MOSI	O	34	Pull-up
SCK	O	35	Pull-up
TEST	I	26	Schmitt-trigger, Pull-down
GP3	B	29	Pull-up
RXD	I	32	Pull-up
TXD	O	33	Pull-up
RI_N	I	34	Pull-up
DCD	I	35	Pull-up
SHTD_N	O	37	Pull-up
GP2	B	38	Pull-up
GP1	B	39	Pull-up
GP0	B	40	Pull-up
RESETB	I	42	Schmitt Trigger, Pull-up
XSCO	O	43	12MHz crystal out
XSCI	I	44	12MHz crystal in

11. Outline Diagram

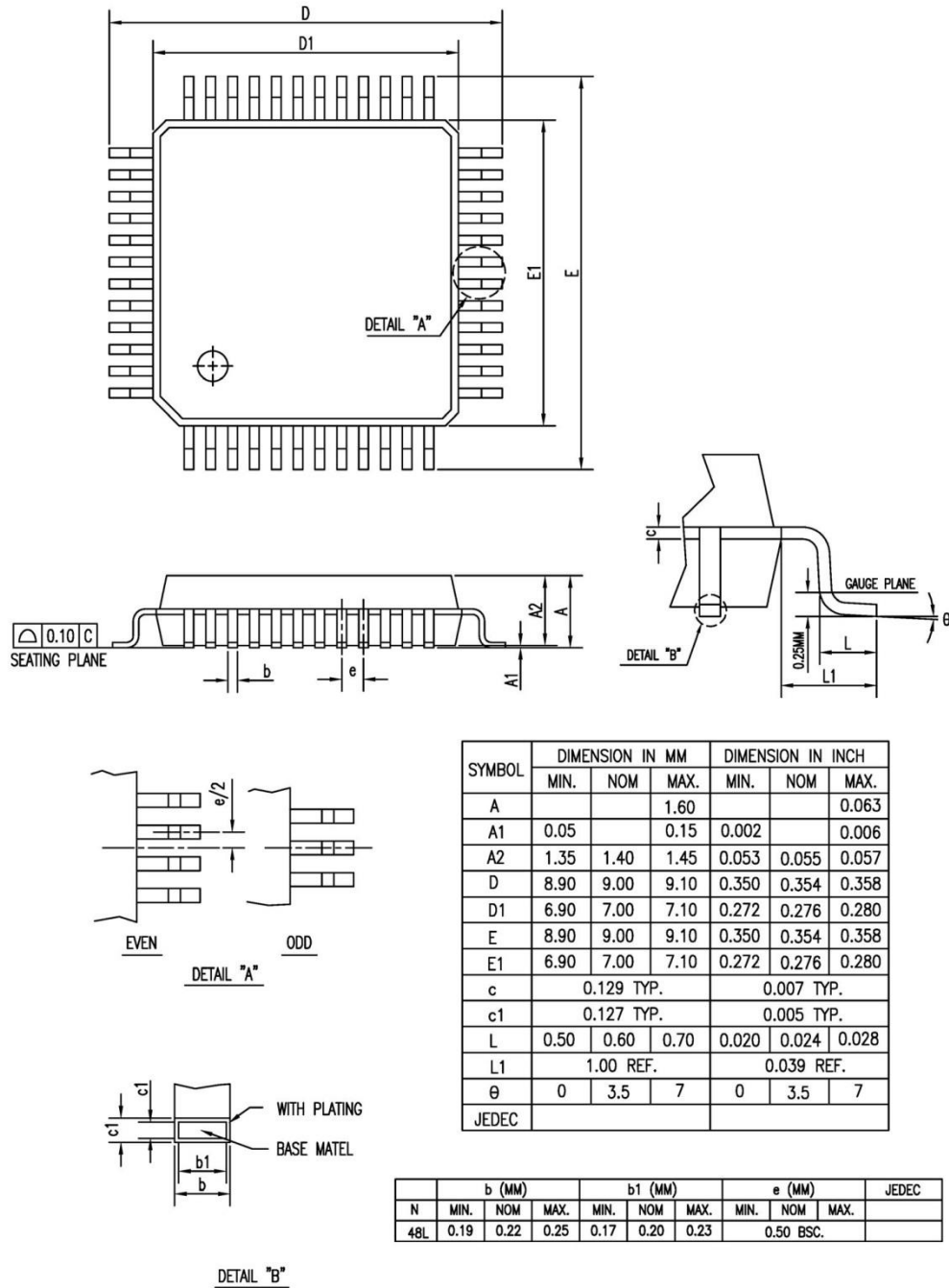

Figure 11-1 Outline Diagram of LQFP48 (7x7mm)

Disclaimer

All the information in this document is subject to change without prior notice. Prolific Technology Inc. does not make any representations or any warranties (implied or otherwise) regarding the accuracy and completeness of this document and shall in no event be liable for any loss of profit or any other commercial damage, including but not limited to special, incidental, consequential, or other damages.

Trademarks

The Prolific logo is a registered trademark of Prolific Technology Inc. All brand names and product names used in this document are trademarks or registered trademarks of their respective holders.

Copyrights

Copyright © 2014-2018 Prolific Technology Inc. All rights reserved.

No part of this document may be reproduced or transmitted in any form by any means without the express written permission of Prolific Technology Inc.